



**CUADERNO PDF**

**1º EDUCACIÓN PRIMARIA**



**CONCEPTOS**

**OPUESTOS**



[WWW.MATEMATICASINCLUSIVAS.COM](http://WWW.MATEMATICASINCLUSIVAS.COM)



Observa los **mathsters** y colorea: **alto** y **bajo**

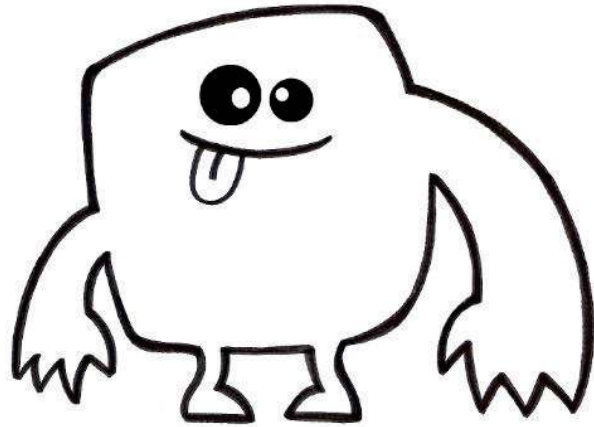
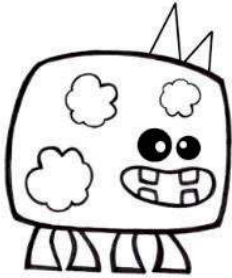

Vicente Molinero Claramunt

Observa los **mathsters**, colorea y escribe: **alto** y **bajo**

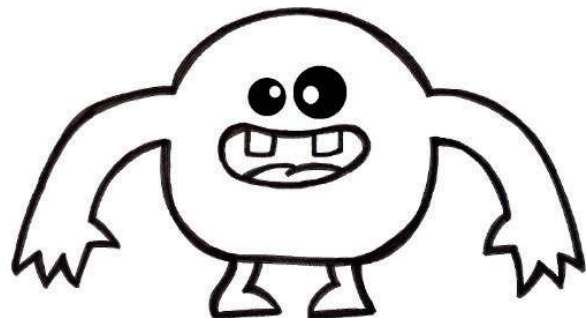
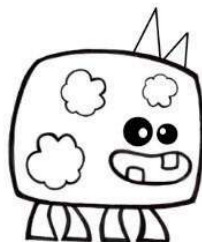



Vicente Molinero Claramunt

Observa los **objetos** y colorea: **largo** y **corto**

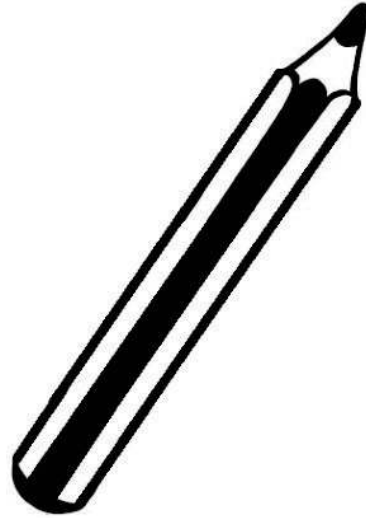

.....

.....

Observa las imágenes, colorea y escribe: **largo** y **corto**

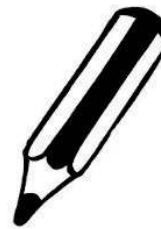
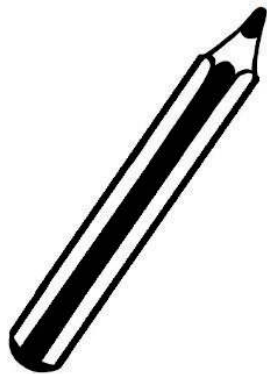

.....

.....

.....

.....

.....

.....

Observa las **puertas** y colorea: **abierto** y **cerrado**

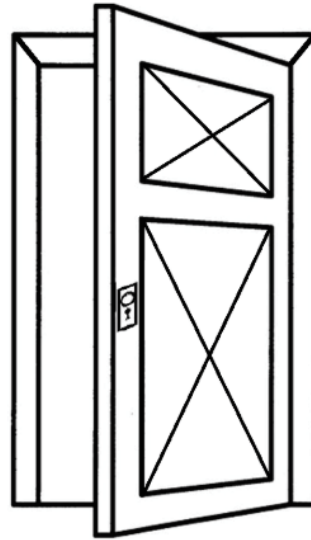
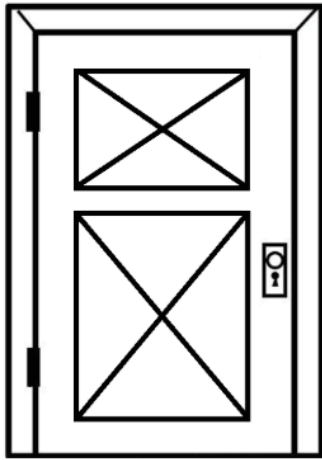

.....

.....

Observa las imágenes, colorea y escribe: **abierto** y **cerrado**

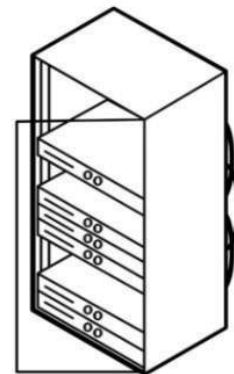

.....

.....

.....

.....

.....

.....

Observa los **mathsters** y colorea: **ancho** y **estrecho**

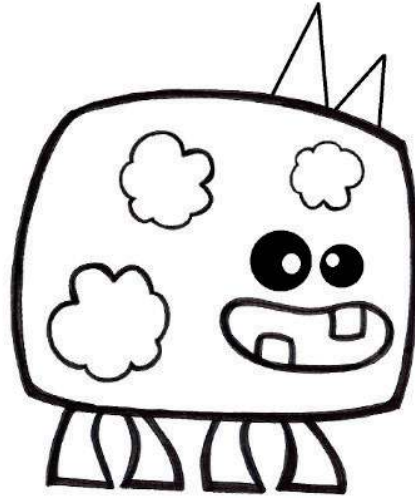
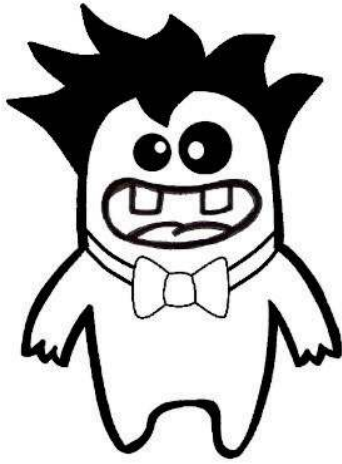

Observa los **mathsters**, colorea y escribe: **ancho** y **estrecho**

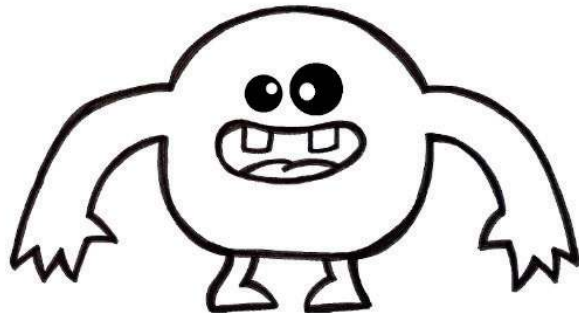

Blank writing box with horizontal lines.

Blank writing box with horizontal lines.

Observa los **mathsters** y colorea:  
**grande, mediano y pequeño**

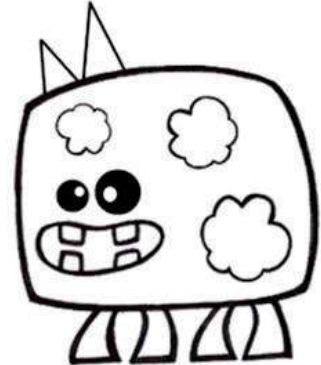
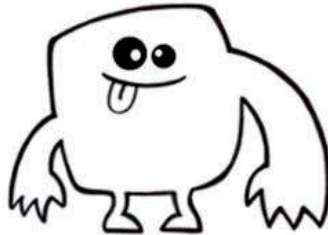
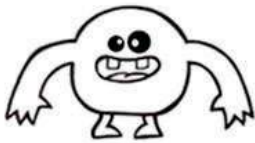

.....  
.....

Observa los **mathsters**, colorea y escribe: **grande, mediano y pequeño**

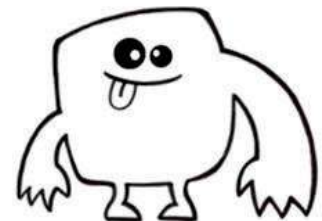
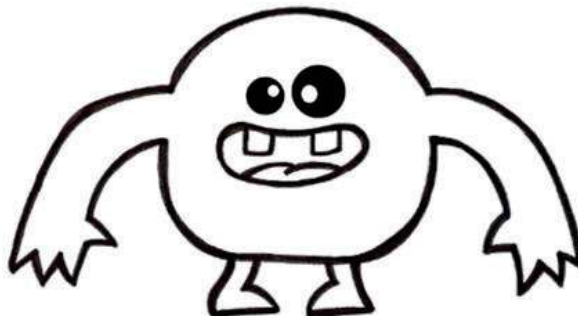
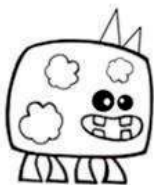

.....  
.....  
.....

.....  
.....  
.....

.....  
.....  
.....

.....  
.....

Ordena los **mathsters** temporalmente: **antes** y **después**

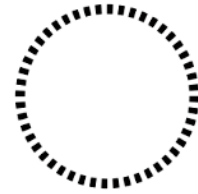
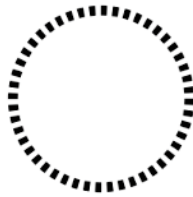
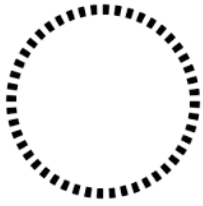
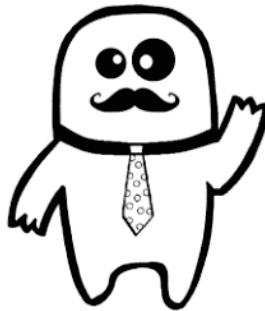

Ordena los **mathsters** temporalmente: **antes** y **después**

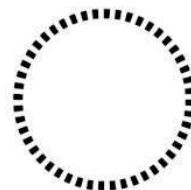
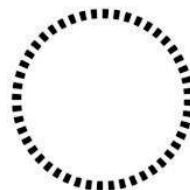
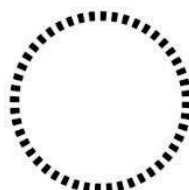
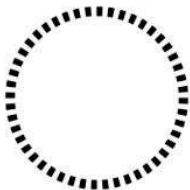
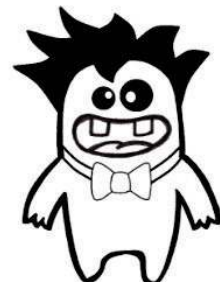
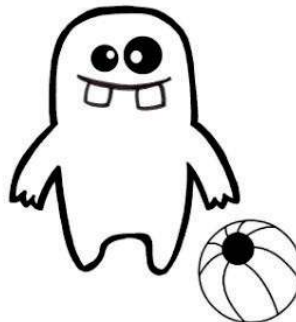
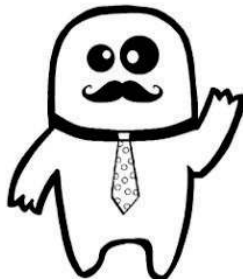

Observa los **objetos** y colorea: **grueso** y **fino**

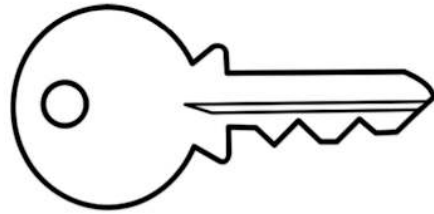
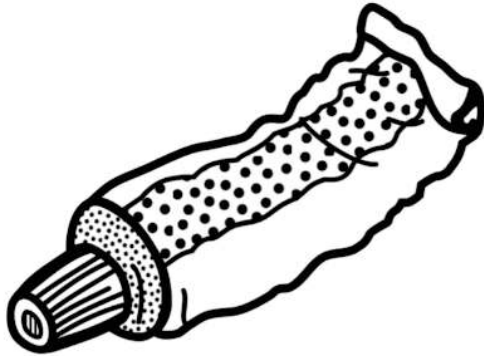

.....

.....

Observa los **objetos**, colorea y escribe: **grueso** y **fino**

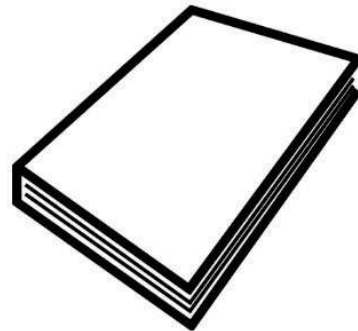
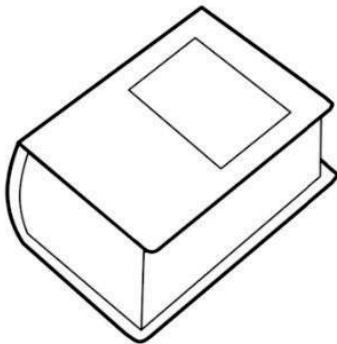

.....

.....

.....

.....

.....

.....



Observa los **objetos** y colorea: **lleno** y **vacío**

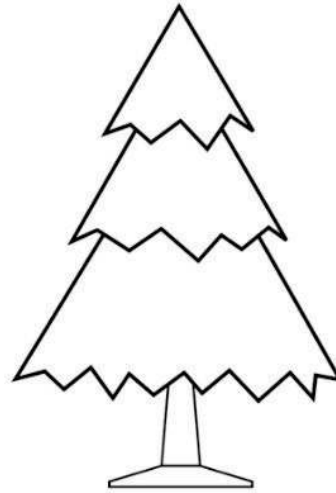

.....

.....

Observa los **objetos**, colorea y escribe: **lleno** y **vacío**

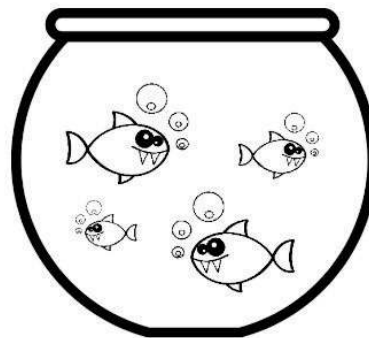
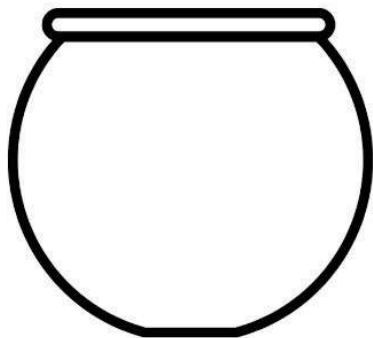



.....

.....

Observa los **objetos** y colorea: **pesado** y **ligero**

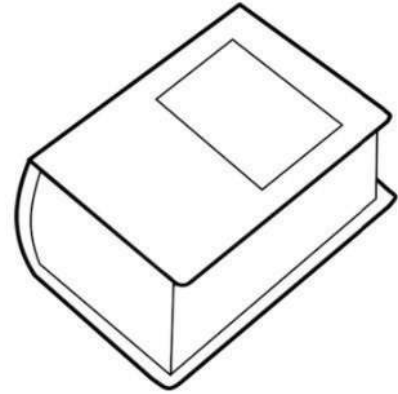
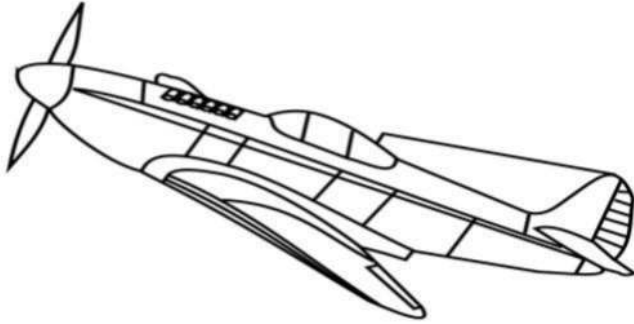

.....  
.....

Observa los **objetos**, colorea y escribe: **pesado** y **ligero**

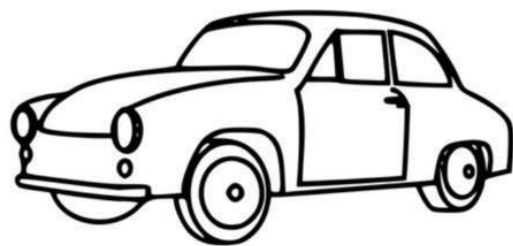
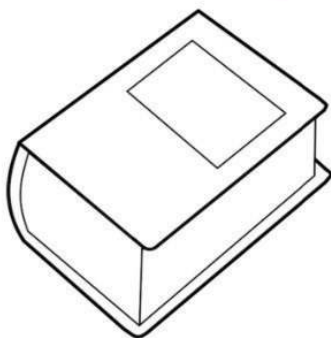

.....  
.....

.....  
.....

.....  
.....

OBSERVA LA AVIONETA Y DESCRIBE SUS PARTES:

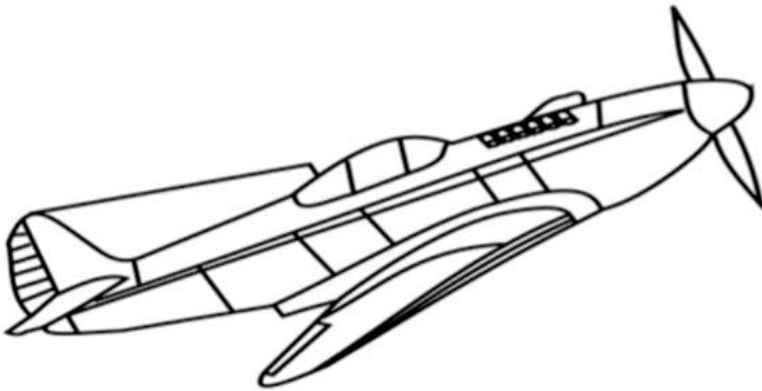

¿QUÉ PASARÍA SI LE  
FALTASE EL MOTOR?

¿QUÉ PASARÍA SI LE  
FALTASEN LAS ALAS?

¿Y QUÉ PASARÍA SI LE  
FALTASE LA HÉLICE?

Vicente Molinero Claramunt

OBSERVA LA HORMIGA Y DESCRIBE SUS PARTES:

¿QUÉ PASARÍA SI LE  
FALTASEN LAS ANTENAS?

¿QUÉ PASARÍA SI LE  
FALTASEN TRES PATAS?

¿Y QUÉ PASARÍA SI LE  
FALTASE EL HORMIGUERO?

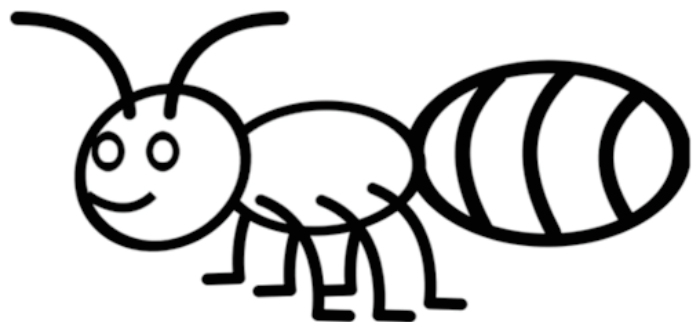

Vicente Molinero Claramunt