



CUADERNO PDF

3º EDUCACIÓN PRIMARIA



**CUERPOS
GEOMÉTRICOS**



WWW.MATEMATICASINCLUSIVAS.COM



(3º_Fig_17) Clasificar cuerpos geométricos por su forma: Prisma - Pirámide.

Colorea y escribe: **prisma** y **pirámide**

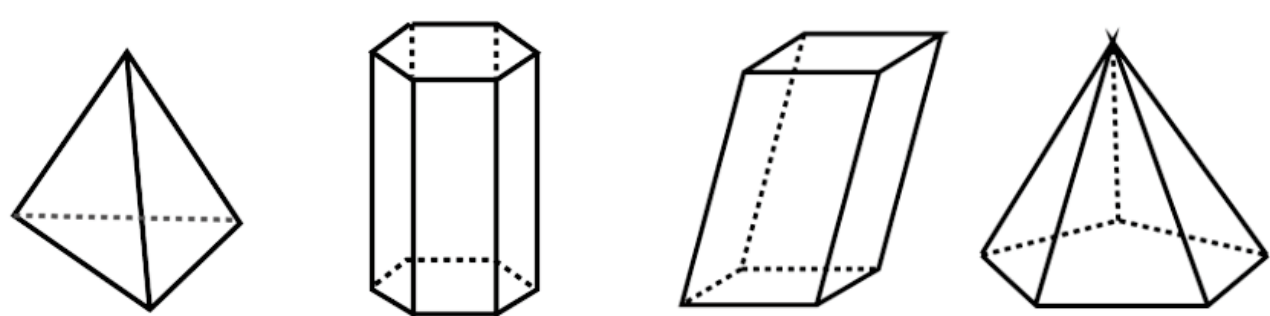

Below each solid is a rectangular box with three horizontal lines for writing.

.....
.....

Vicente Molinero Claramunt

(3º_Fig_17) Clasificar cuerpos geométricos por su forma: Prisma - Pirámide.

Colorea y escribe: **prisma** y **pirámide**

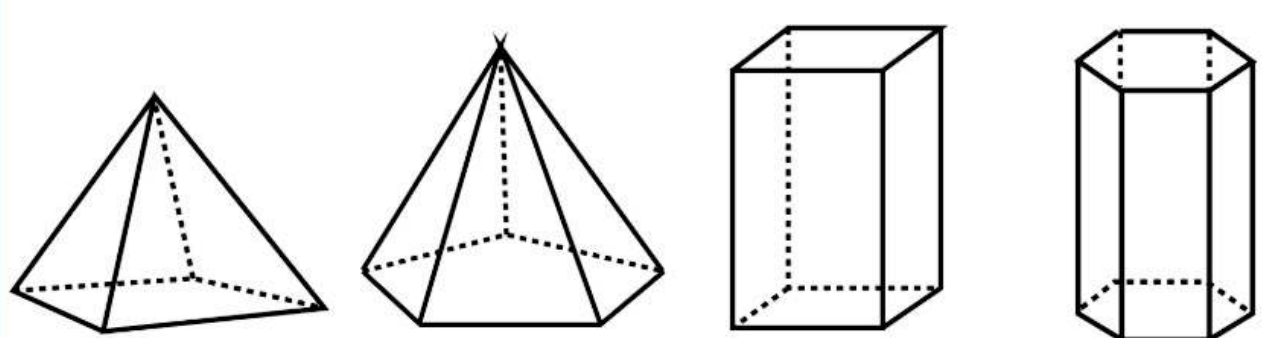

Below each solid is a rectangular box with three horizontal lines for writing.

.....
.....

Vicente Molinero Claramunt

Colorea las caras laterales y la base de los prismas:

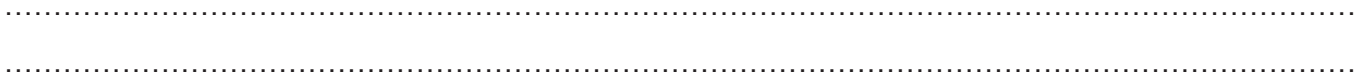
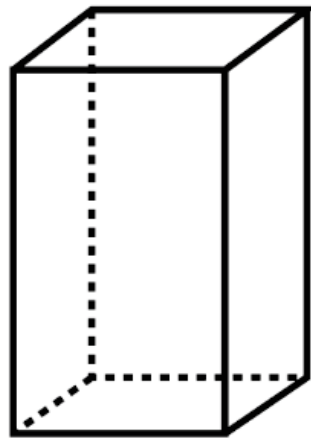
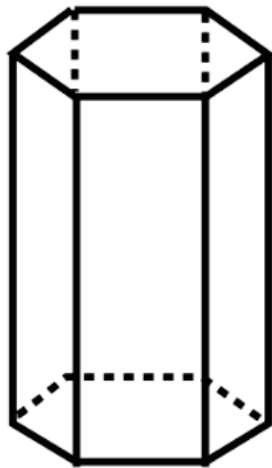

Colorea las caras laterales y la base de los prismas:

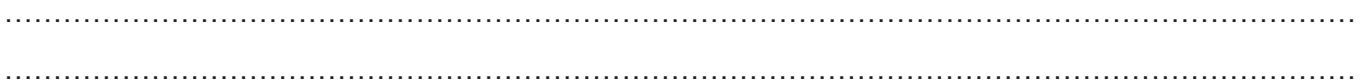
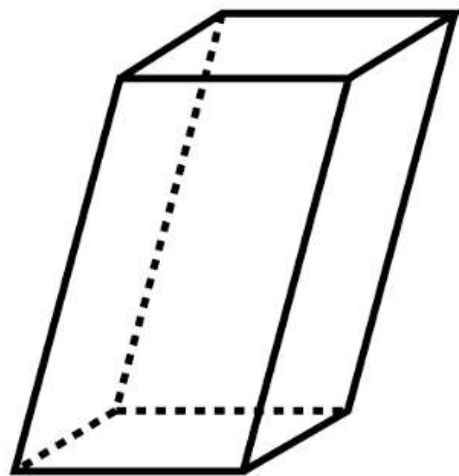
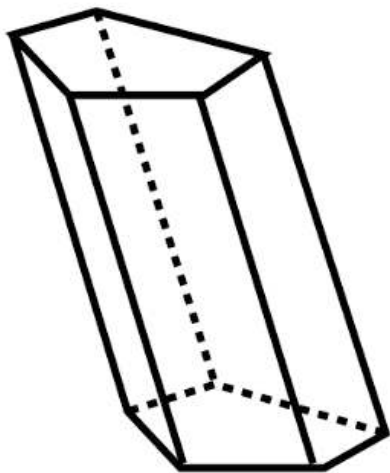

Colorea las caras laterales y la base de las pirámides:

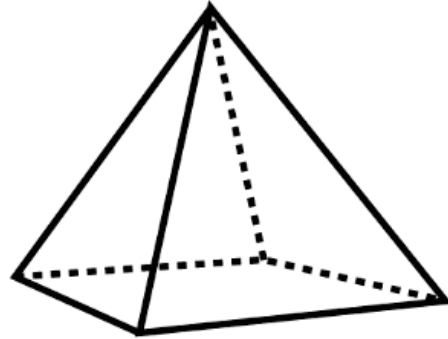
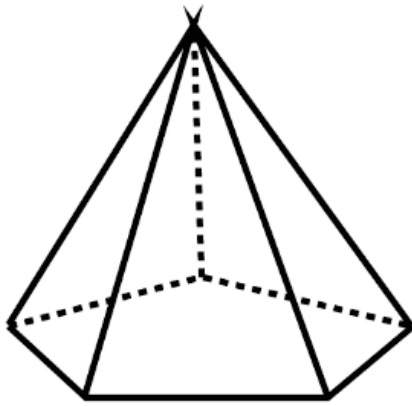

.....

.....

Colorea las caras laterales y la base de las pirámides:

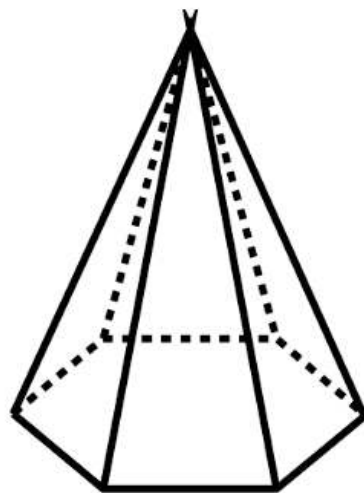
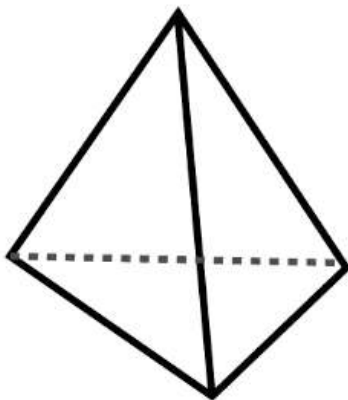

.....

.....

Observa y colorea el **cilindro**, el **cono** y la **esfera**:

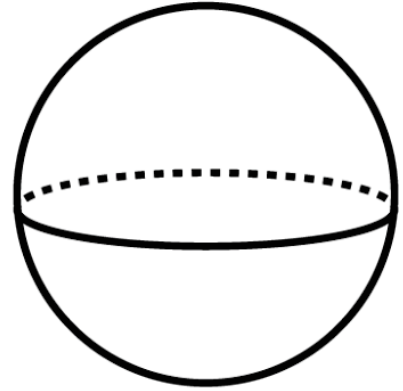
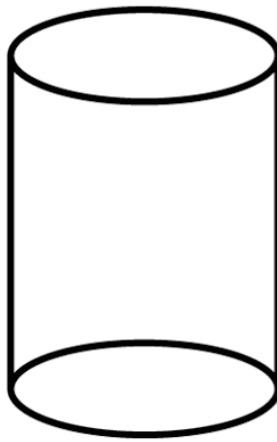
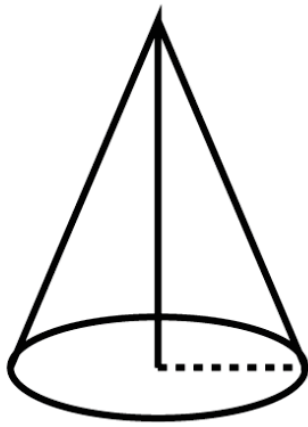

.....

.....

Colorea y escribe: **cilindro**, **cono** y **esfera**

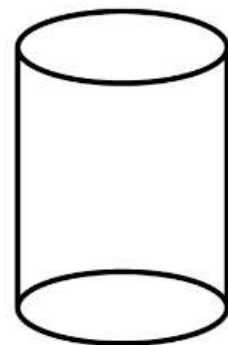
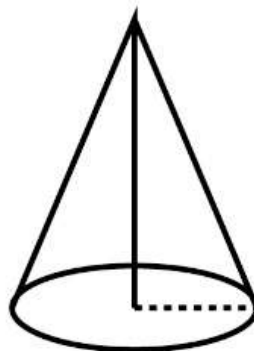
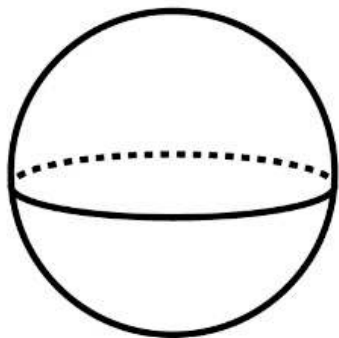

.....

.....

.....

.....

.....

.....

.....

.....

Colorea las figuras: **prisma**, **pirámide**, **cilindro**, **cono** y **esfera**

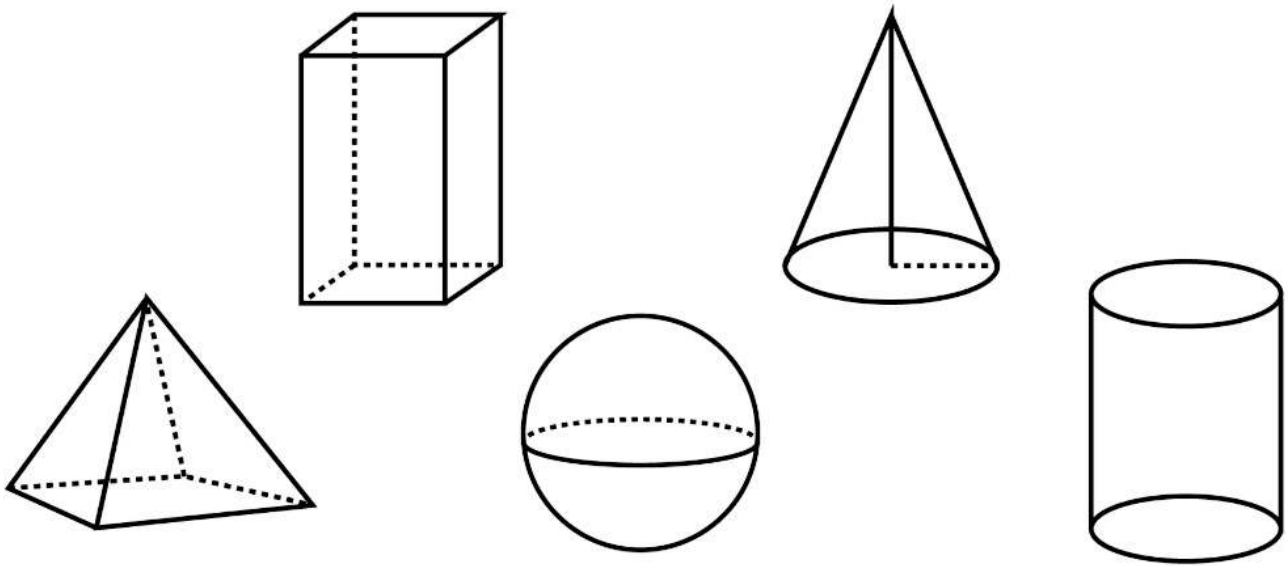

.....
.....

Colorea las figuras: **pirámide**, **cono**, **esfera**, **cilindro** y **prisma**

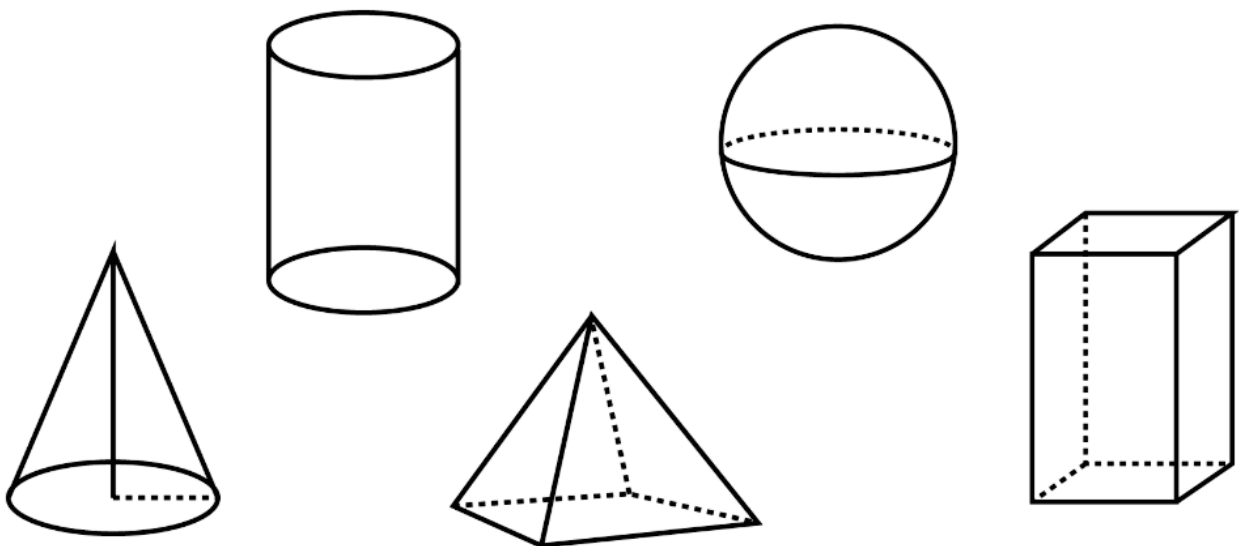

.....
.....

(3º_Fig_22) Clasificar cuerpos geométricos según sus caras y superficie: Poliedro - No poliedro.

Colorea las figuras geométricas: **poliedros** y **no poliedros**

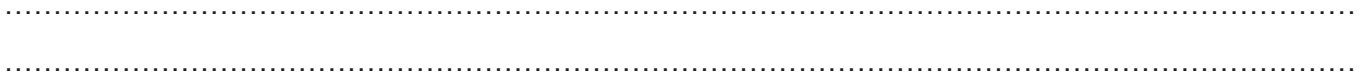
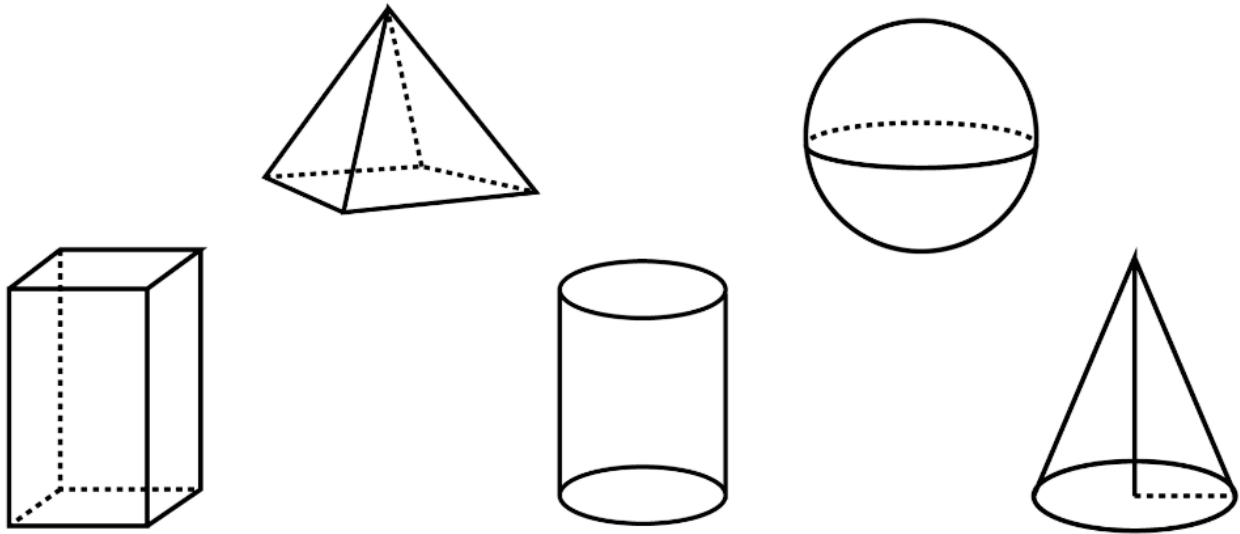

Vicente Molinero Claramunt

(3º_Fig_22) Clasificar cuerpos geométricos según sus caras y superficie: Poliedro - No poliedro.

Colorea las figuras geométricas: **poliedros** y **no poliedros**

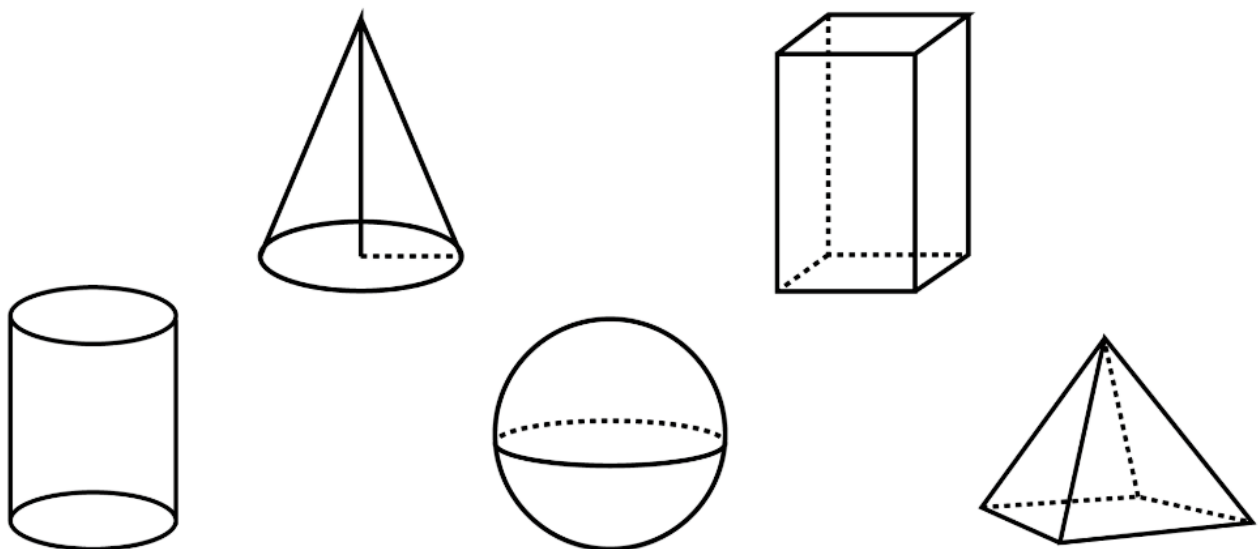

Vicente Molinero Claramunt

(3º - Fig. 23) Clasificar cuerpos geométricos según sus caras y superficie: Redondo - No redondo.

Colorea los **cuerpos redondos** y los **cuerpos no redondos**:

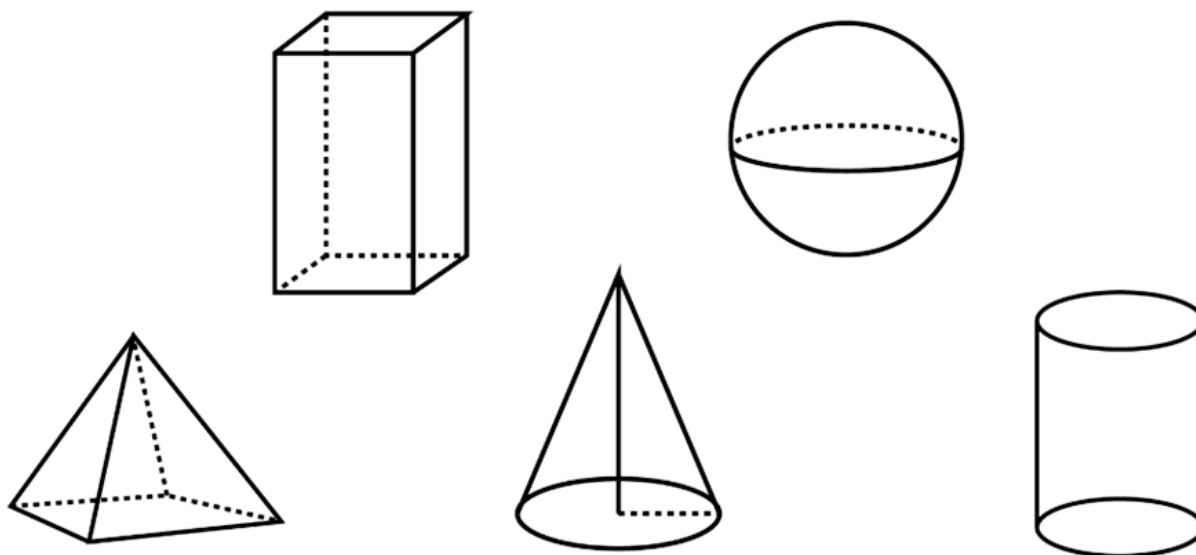

.....

.....

Vicente Molinero-Caramunt

(3º - Fig. 23) Clasificar cuerpos geométricos según sus caras y superficie: Redondo - No redondo.

Colorea los **cuerpos redondos** y los **cuerpos no redondos**:

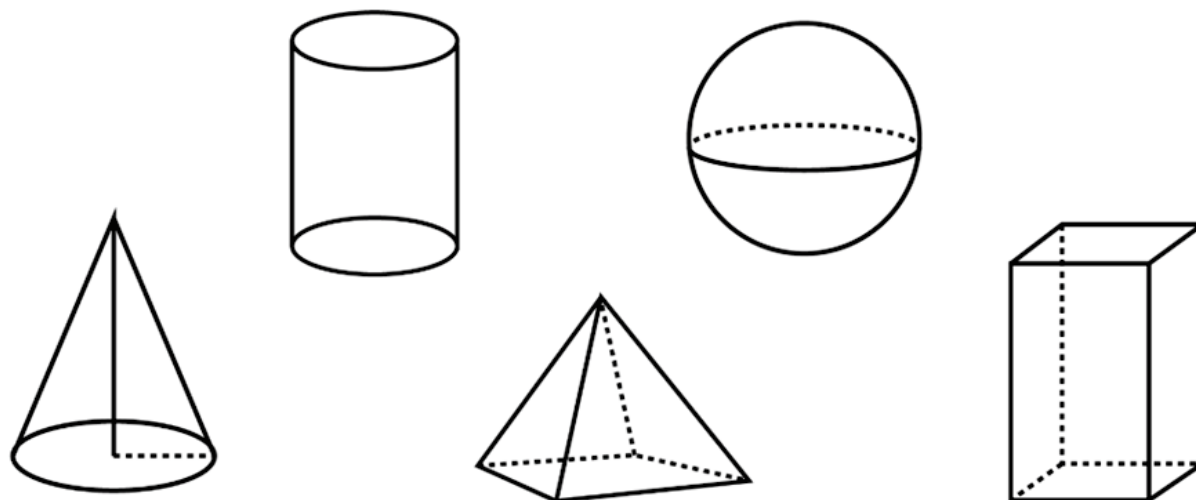

.....

.....

Vicente Molinero-Caramunt

Nombra en la figura geométrica sus elementos: **caras**, **aristas** y **vértices**

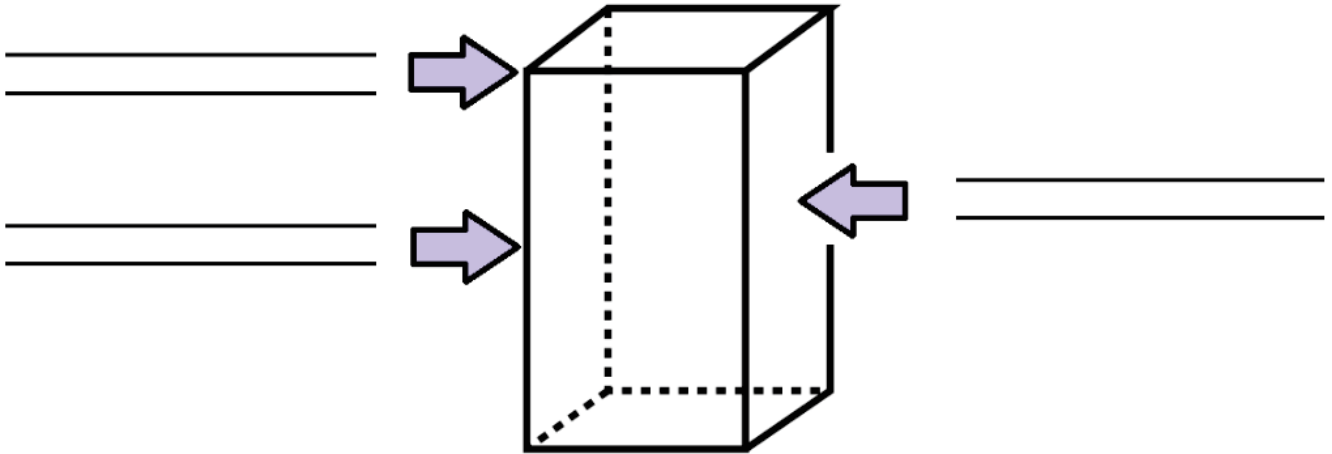

¿La superficie es **plana** o **curva**?

Nombra en la figura geométrica sus elementos: **caras**, **aristas** y **vértices**

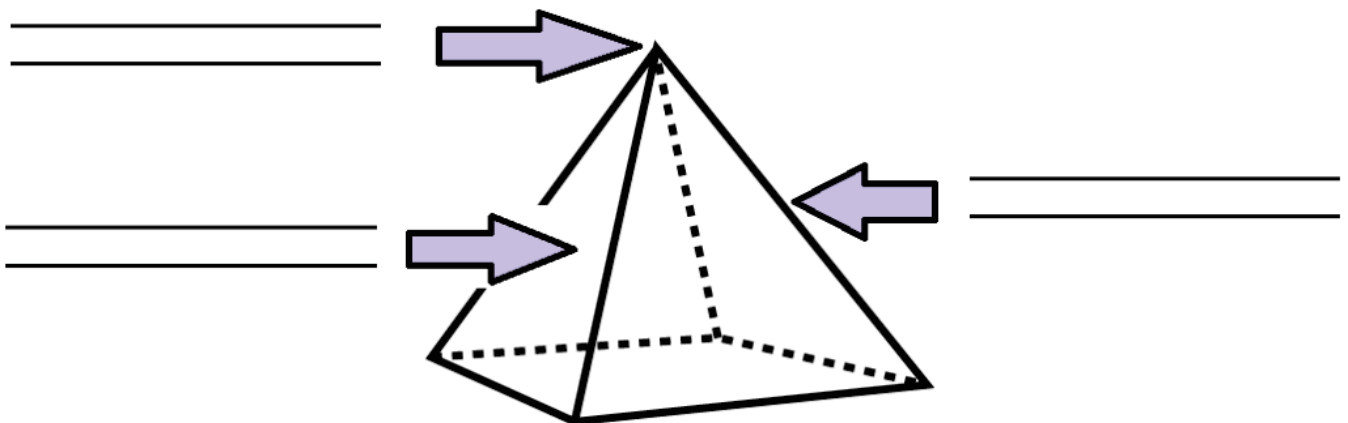

¿La superficie es **plana** o **curva**?

Clasifica los prismas: triangular, cuadrangular, pentagonal y hexagonal

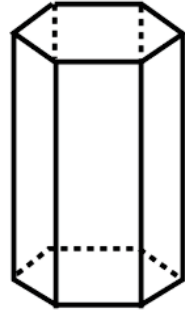
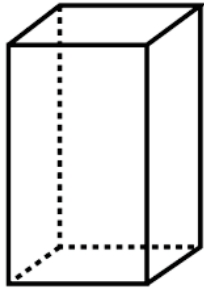

.....

.....

Clasifica los prismas: triangular, cuadrangular, pentagonal y hexagonal

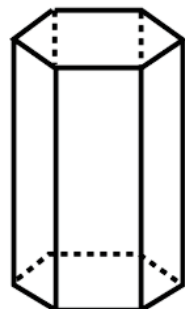
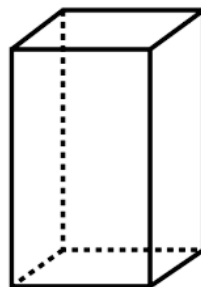

.....

.....

Clasifica las pirámides: triangular, cuadrangular, pentagonal y hexagonal

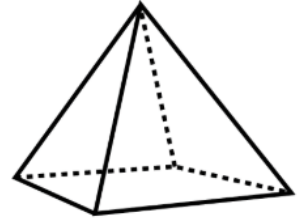
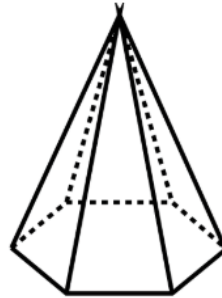
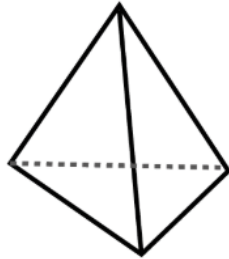
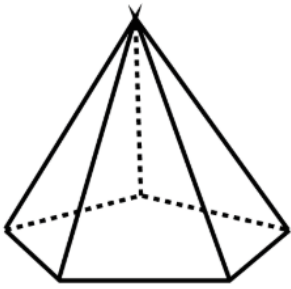

.....

.....

Clasifica las pirámides: triangular, cuadrangular, pentagonal y hexagonal

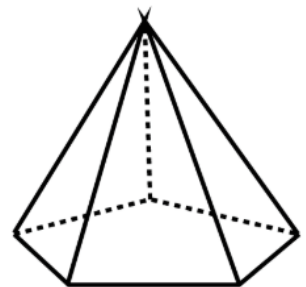
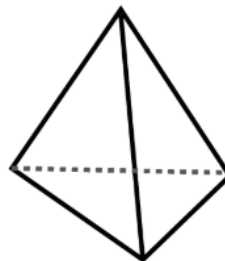
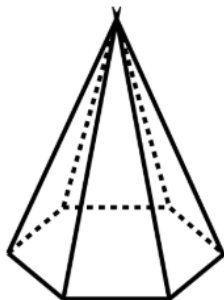
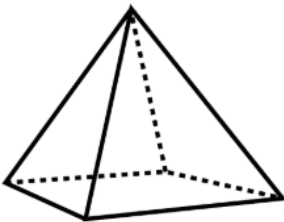







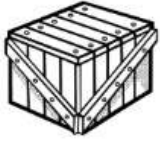
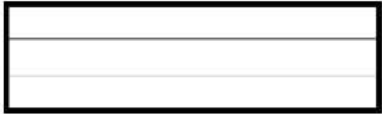

.....

.....

(3º_Fig_27) Reconocer y describir formas y cuerpos geométricos entre los objetos del entorno:

Escribe la **forma geométrica** que representan los **objetos**:

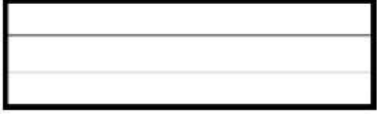

.....

.....

Vicente Molinero-Caramunt

(3º_Fig_27) Reconocer y describir formas y cuerpos geométricos entre los objetos del entorno:

 Dibuja **dos objetos** con **forma de cuadrado**:

.....

.....

Vicente Molinero-Caramunt